

DASH NO.	GLASS	PART NUMBER
-KK	KK1	-EXAMPLE-
-S	KSF5	B A2513 - 332 - KK
-SS	KSF10	
-K	KF2	REV DRAWING NO. LENGTH MATERIAL
-C	KC331	
-Q	QUARTZ	NO SOAK, LIGHT FIRE POLISH ON ENDS

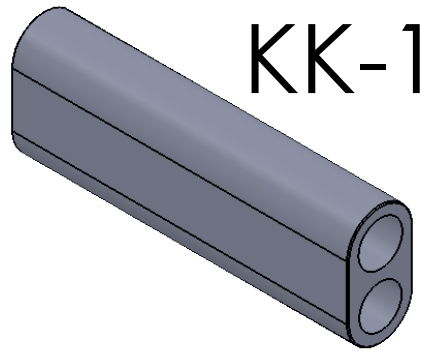

KK-1

NO.	NOTES
1	▶ BLANK CUT LENGTH = L + 0.5".
2	L=LASER ROD LENGTH - 0.680" (USE 3.0" FOR 80 mm).
3	POLISH INSIDE AND OUT TO CLARITY, TO 80 - 50 SCRATCH - DIG.
4	ENDS-FINE GROUND & CHAMFER ON O.D. & I.D. 0.005" - 0.010".
5	STRENGTHEN - 3 DAY SOAK. (EXCEPT WHERE NOTED).

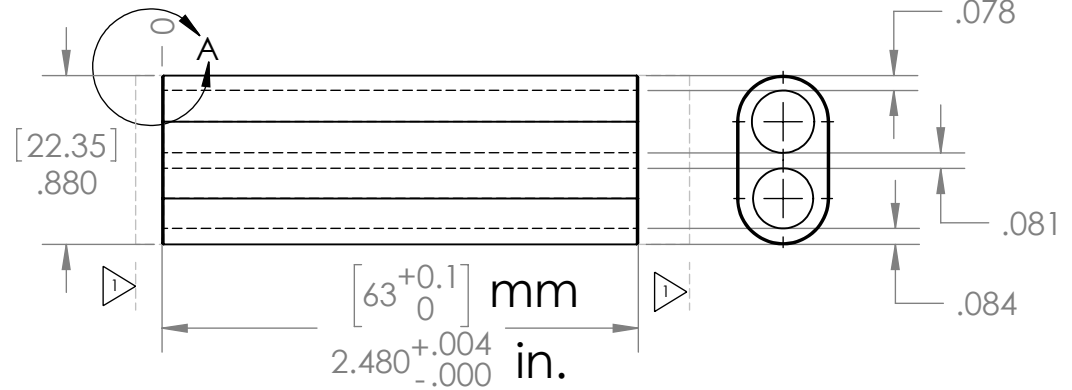
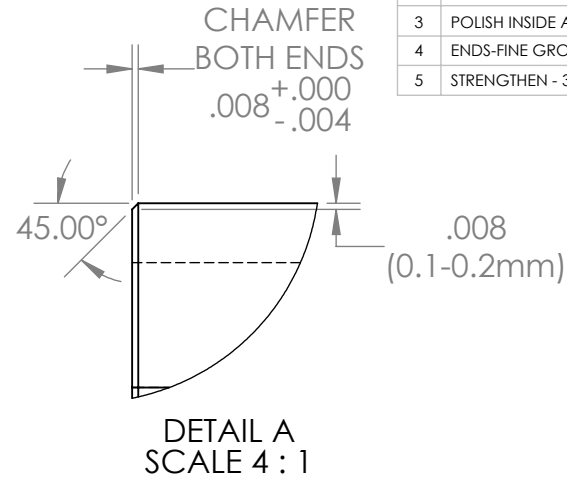
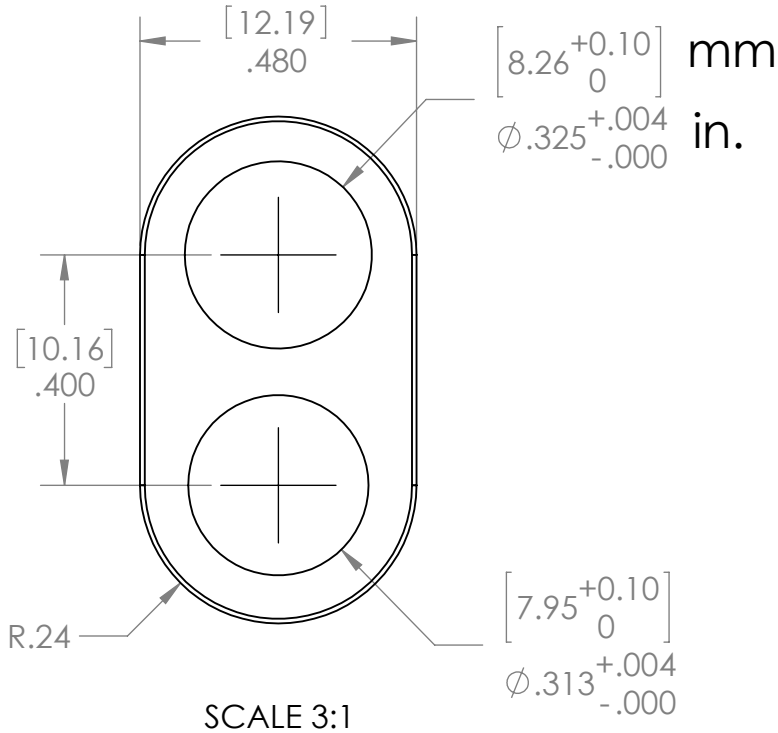

UNLESS OTHERWISE SPECIFIED:		NAME	DATE
DIMENSIONS ARE IN INCHES (EXCEPT WHERE NOTED)		DRAWN	CRH 30SEP16
TOLERANCES:		CHECKED	JMM 30SEP16
ONE PLACE DECIMAL ±0.020		ENG APPR.	
TWO PLACE DECIMAL ±0.010		MFG APPR.	
THREE PLACE DECIMAL ±0.005		Q.A.	
INTERPRET GEOMETRIC TOLERANCING PER:		COMMENTS:	
MATERIAL		SEE CHART	
FINISH		SEE NOTES	
DO NOT SCALE DRAWING			

L3 L3 KIGRE, INC.

TITLE: **TUBE, FILTER - 400/2**

SIZE	DWG. NO.	REV
A	A1255-63mm-KK	1

SCALE: 1:1 WEIGHT: SHEET 1 OF 1

REV	DATE	DESCRIPTION	BY	APPR
1	14JAN10	HOLE TOLERANCE CHANGED FROM ±0.005 TO -0.000 -- +0.004	CXY	CRH
		NEXT ASSY	USED ON	
		APPLICATION		