

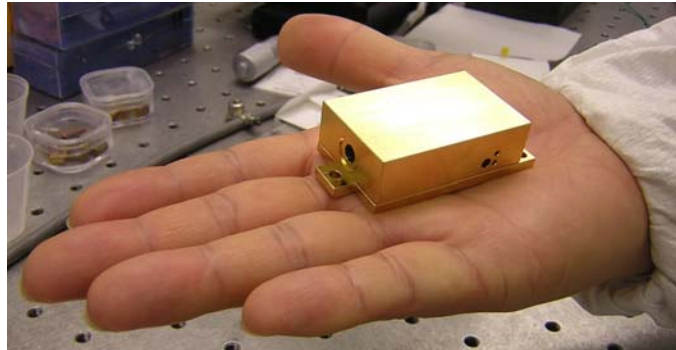

**MK-85**

# **SS-10Hz, 3mj, 7ns**

**Diode Pumped Eye-Safe Microlaser**

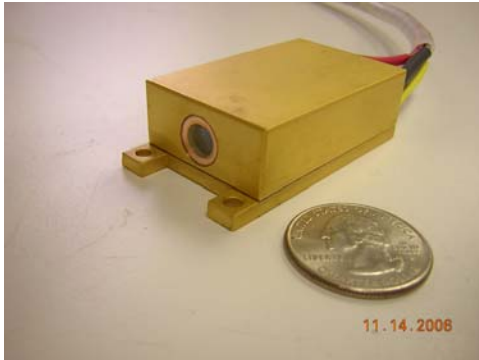

**Diode Pumped Solid State (DPSS)**  
**High Efficiency Side Pumped (HESP) Laser**

<b>Laser Wavelength</b>	<b>1534 nm</b>
<b>Pump Voltage &amp; Amps</b>	<b>4V, 100A</b>
<b>Output Energy</b>	<b>~ 2 to 3mj</b>
<b>Laser Output Pulsewidth</b>	<b>~ 6ns</b>
<b>Raw Beam Diameter</b>	<b>0.8mm</b>
<b>Beam Divergence</b>	<b>~ 4.2mrad</b>
<b>Beam Wander</b>	<b>&lt;0.5mrad</b>
<b>Pulse Rep-rate</b>	<b>SS - 10 Hz</b>
<b>Laser Head Size</b>	<b>0.65" x 1.2" x 2.19"</b>
<b>Laser Head Weight</b>	<b>135 grams</b>
<b>Conductive Cooling Requirements</b>	<b>~ 10 watts*</b>
<b>Operating Temperature Range</b>	<b>-30 to +50 °C</b>
<b>Storage Temperature</b>	<b>-55 to +90°C</b>
<b>* See Example Duty Cycle Info</b>	
<b>Spectral Bandwidth FWHM 4.5nm</b>	<b>10% points 8nm</b>

**KIGRE, INC.**, 100 Marshland Road, Hilton Head, SC 29926  
PH:(843) 681-5800 FAX: (843) 681-4559 Web site: [www.kigre.com](http://www.kigre.com)  
E-mail: [info@kigre.com](mailto:info@kigre.com)



**KIGRE, INC.**



## **MK-88 & MK-830 Engineering Notes**

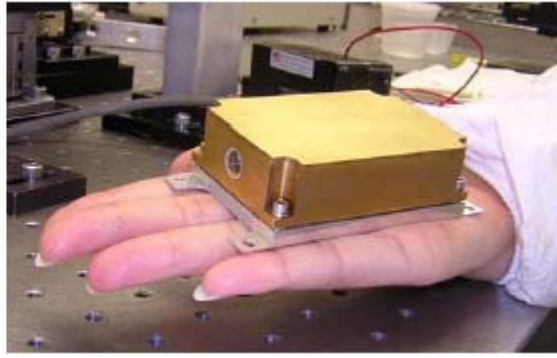

Using a fan and heat sink the MK88 laser is typically operated up to its maximum duty cycle: 10Hz, 30 second burst (300 shots) followed by a cool down period of at least 1 minute.

Using a fan and heat sink the MK830 laser is typically operated up to its maximum duty cycle: 30Hz, 30 second burst (900 shots) followed by a cool down period of at least 2 minutes.

Water cooled baseplates are also acceptable. Active cooling must be used to operate at the maximum duty cycle. A good method for monitoring the laser's internal temperature is to look at the pump current pulse width. Specifically, this pulse width should not exceed 3 milliseconds. You'll notice that the pump pulse width will increase as the laser heats up. This is due to the loss of efficiency. Once the pump pulse width gets beyond 3mS, the efficiency of the laser drops dramatically and the pump pulse width will rise quickly - indicating an overheated condition. Please do not operate the laser if the pump current pulse width exceeds 3mS.

We suggest the use of a Tektronix model # A622 probe. The probe should be located between the driver and the laser. You can clip on a section of the red wire anywhere in the laser cable.

Datasheet for current probe:

<http://www2.tek.com/cmswpt/psdetails.lotr?ct=PS&ci=13510&cs=psu&lc=EN>

To purchase the probe:

<http://www.alliedelec.com/search/productdetail.aspx?SKU=7000622>

**KIGRE, INC.**, 100 Marshland Road, Hilton Head, SC 29926  
PH:(843) 681-5800 FAX: (843) 681-4559 Web Site: <http://www.kigre.com>  
E-mail: [info@kigre.com](mailto:info@kigre.com)



## MK-830-PS Laboratory Diode Driver

Kigre's MK-830-PS laboratory laser diode driver is for use with the MK-830, MK-88, MK-85, MK-82, MK-81 and MK-11 laser heads. The driver features precision pulsed current operation and supports the HESP family eye-safe laser diode requirements. A USB cable and software are provided so that the customer may use their computer as a laser controller. The driver operates over an extremely wide AC input voltage range and includes ultra-high performance hold-up capacitors for stable pulsed current control up to 140 Amps. Soft-start control, active current limiting, transient filtering, and a mechanical shorting relay provide robust protection for the laser diode even when power is removed. HESP laser customers are provided electrical engineering support to facilitate HESP laser integration. This includes access to Kigre's laboratory diode driver schematics, surface mount board vendors, parts list, and power supply design support.

The HESP lasers contain a built-in photodiode that is used to turn off the pump pulse as soon as the laser pulse is emitted. The laser's photodiode signal may also be used as a "To" (time zero) for a range counter or other event timing. The pump pulse-width is typically between 1.5 and 2.5ms depending upon the laser head's temperature and operating conditions. We time out the pulse at a maximum of 3.4ms for safety to prevent the pump diodes from runaway CW operation. Laser pump pulses greater than 3ms are near the point of diminishing returns with regard to laser output energy and system efficiency.

A useful method for monitoring the laser's internal temperature is to look at the pump current pulse width. Specifically, this pulse width should not exceed 3 milliseconds. You'll notice that the pump pulse width will increase as the laser heats up. This is due to the loss of efficiency. Once the pump pulse width gets beyond 3mS, the efficiency of the laser drops dramatically and the pump pulse width will rise quickly - indicating an overheated condition. Please do not operate the laser if the pump current pulse width exceeds 3mS.

We suggest the use of a Tektronix model # A622 probe. The probe should be located between the driver and the laser. You can clip on a section of the red wire anywhere in the laser cable.

Datasheet for current probe:

<http://www2.tek.com/cmswpt/psdetails.lotr?ct=PS&ci=13510&cs=psu&lc=EN>

To purchase the probe:

<http://www.alliedelec.com/search/productdetail.aspx?SKU=7000622>

Pump Pulsewidth: Approximately 1.5mS (photodiode feedback controlled)

Internal Photodiode: Hamamatsu # G8376-05 (InGaAs, 0.5mm Ø active area)

Link to Photodiode Datasheet:

[http://sales.hamamatsu.com/assets/pdf/parts\\_G/g8376\\_series\\_kird1051e05.pdf](http://sales.hamamatsu.com/assets/pdf/parts_G/g8376_series_kird1051e05.pdf)

**KIGRE, INC.**, 100 Marshland Road, Hilton Head, SC 29926  
PH:(843) 681-5800 FAX: (843) 681-4559 Web site: [www.kigre.com](http://www.kigre.com)  
E-mail: [info@kigre.com](mailto:info@kigre.com)



## HESP Laser Flying Lead Electrical Interface

Kigre has developed a highly flexible flying lead electronics interface using Teflon coated wire and a unique high strength strain relief support through the enclosure bulkhead. The standard configuration for Kigre's HESP laser products is rear exit flying leads. Side exit flying leads are a custom alternative.

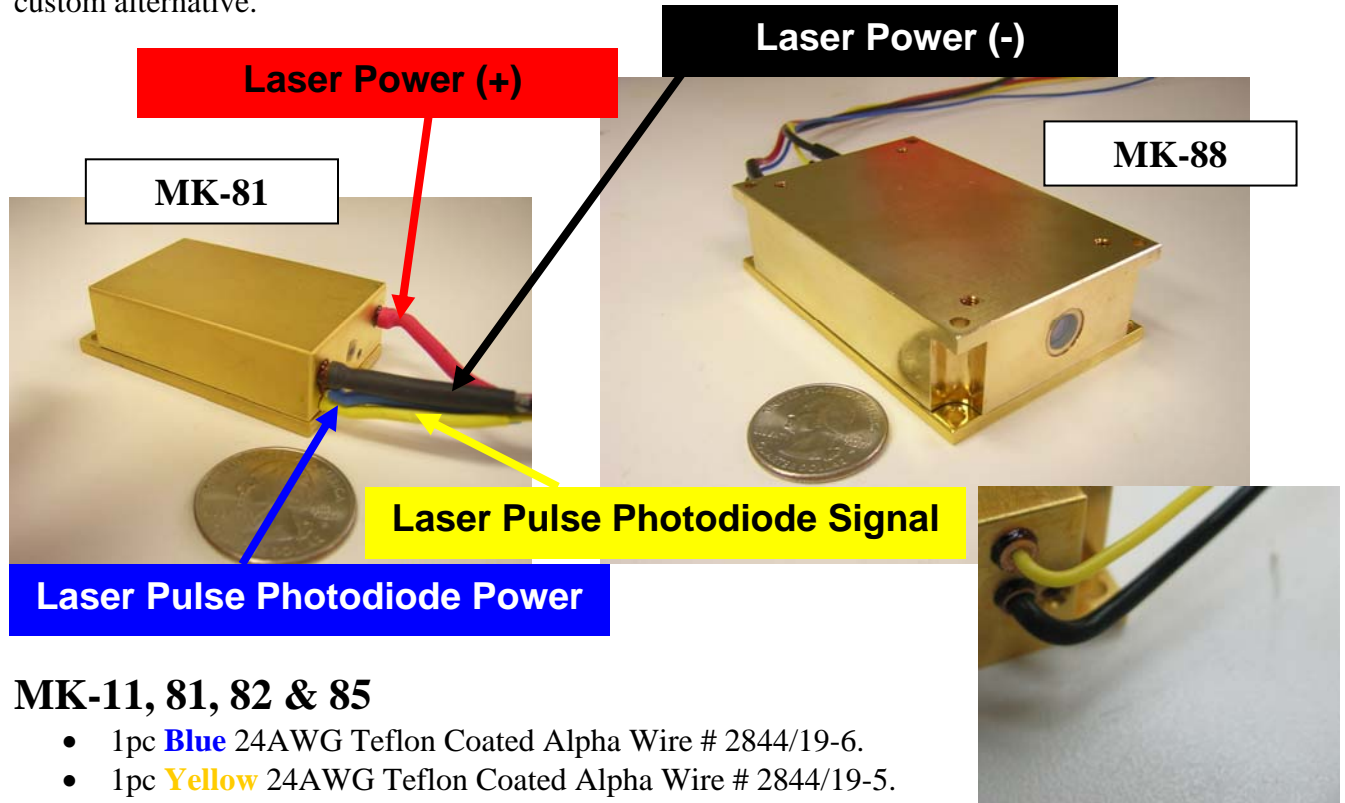

### MK-11, 81, 82 & 85

- 1pc **Blue** 24AWG Teflon Coated Alpha Wire # 2844/19-6.
- 1pc **Yellow** 24AWG Teflon Coated Alpha Wire # 2844/19-5.
- 1pc **Red** 20AWG Teflon Coated Alpha Wire #5856-3.
- 1pc **Black** 20AWG Teflon Coated Alpha wire #5856-2.

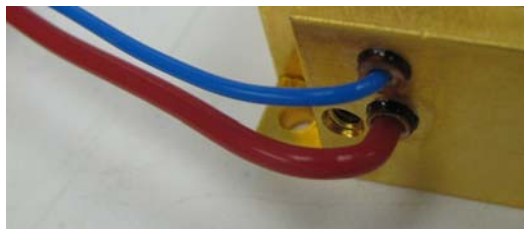

### MK-84, 88 & 830

- 1pc **Blue** 24AWG Teflon Coated Alpha Wire # 2844/19-6.
- 1pc **Yellow** 24AWG Teflon Coated Alpha Wire # 2844/19-5.
- 1pc **Red** 16AWG Teflon Coated Alpha Wire #5858-3.
- 1pc **Black** 16AWG Teflon Coated Alpha wire #5858-2.

REV	DATE	DESCRIPTION	APPR

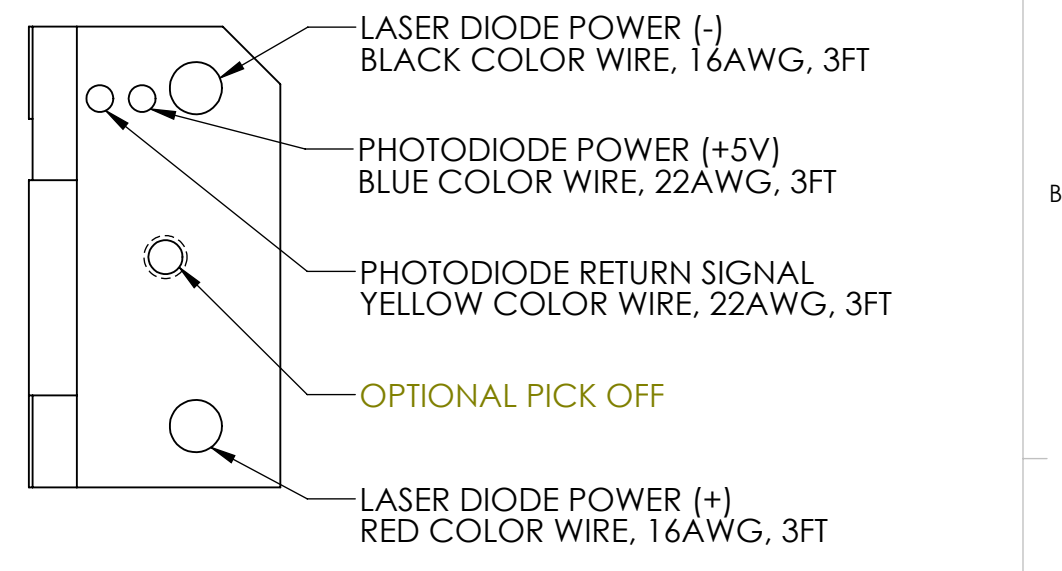
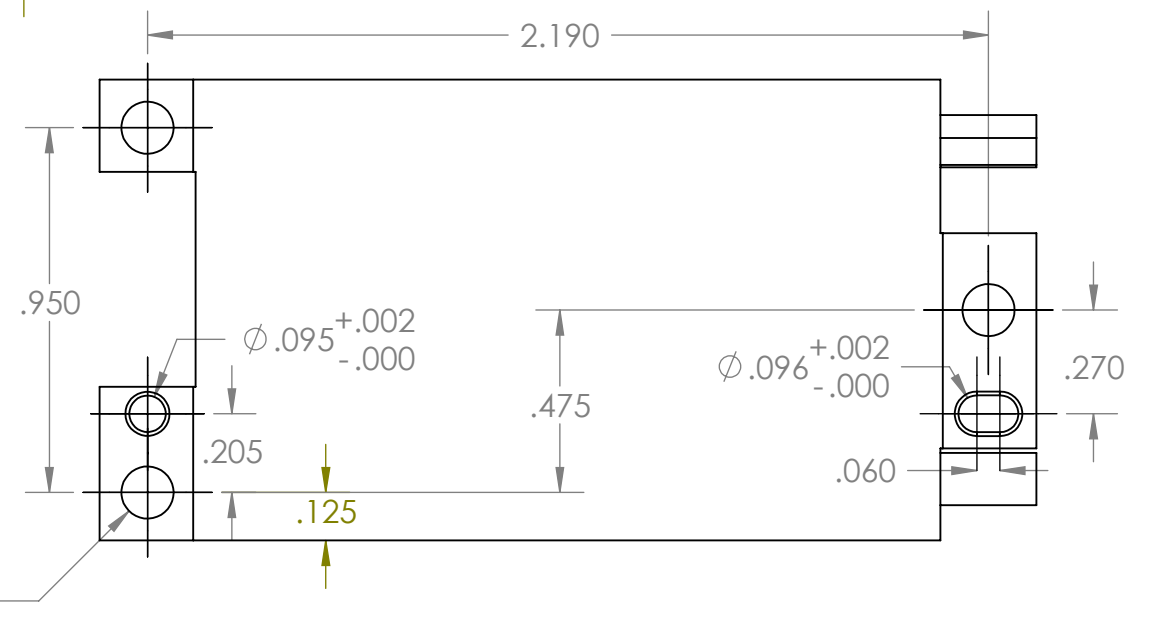
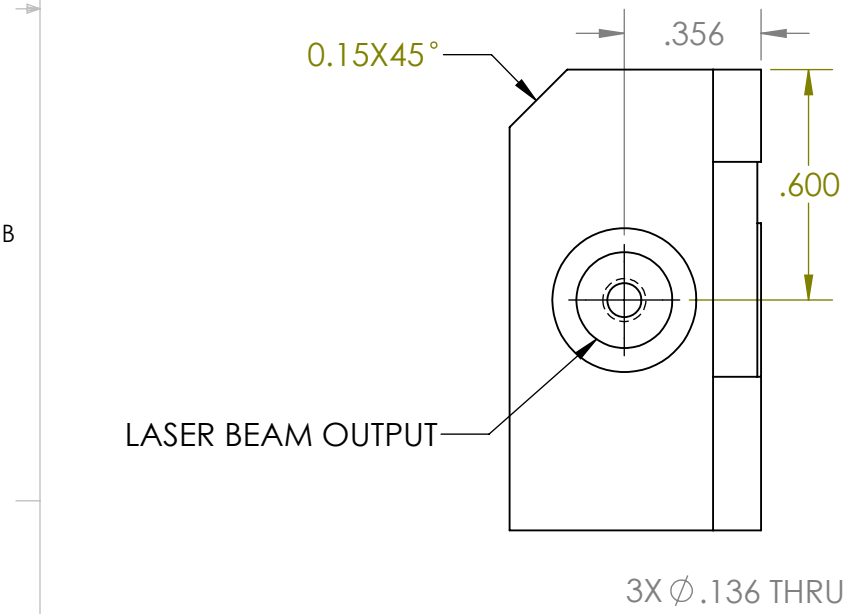
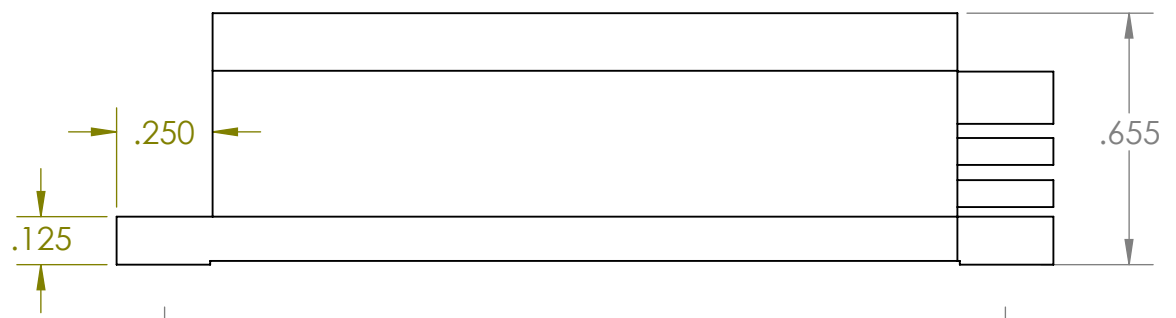
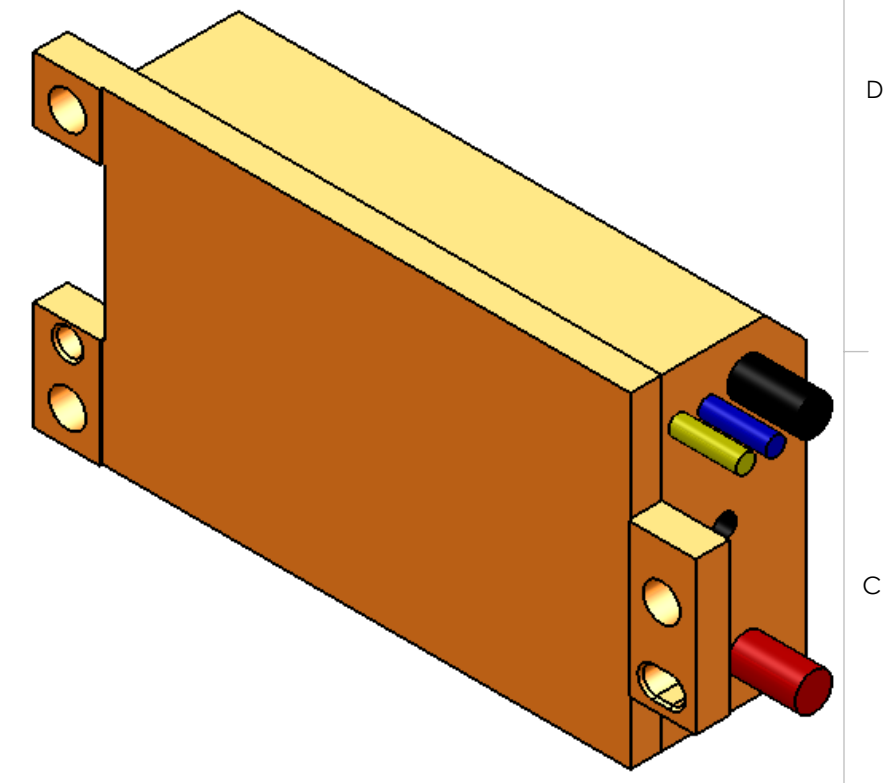
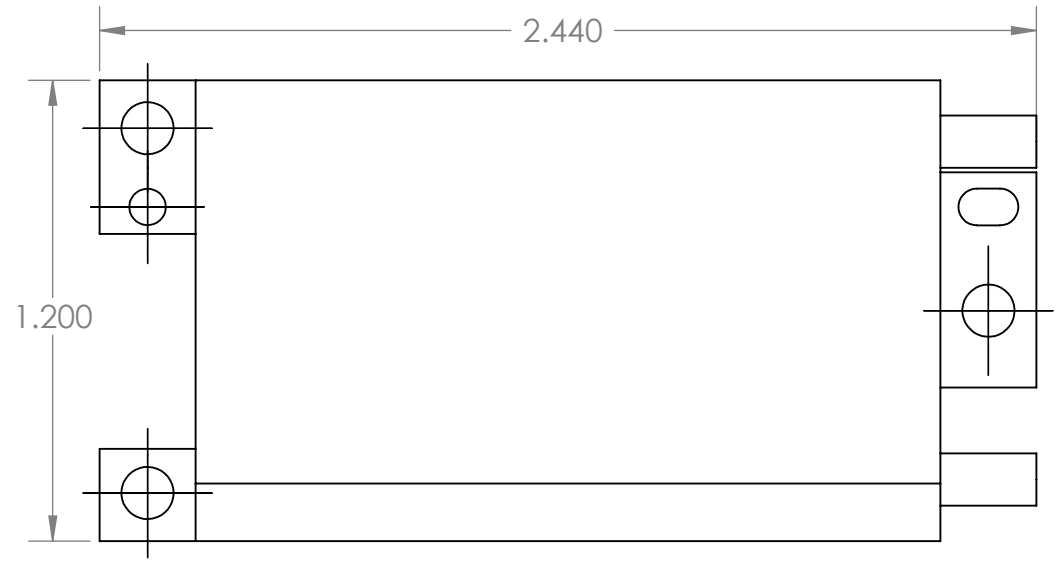
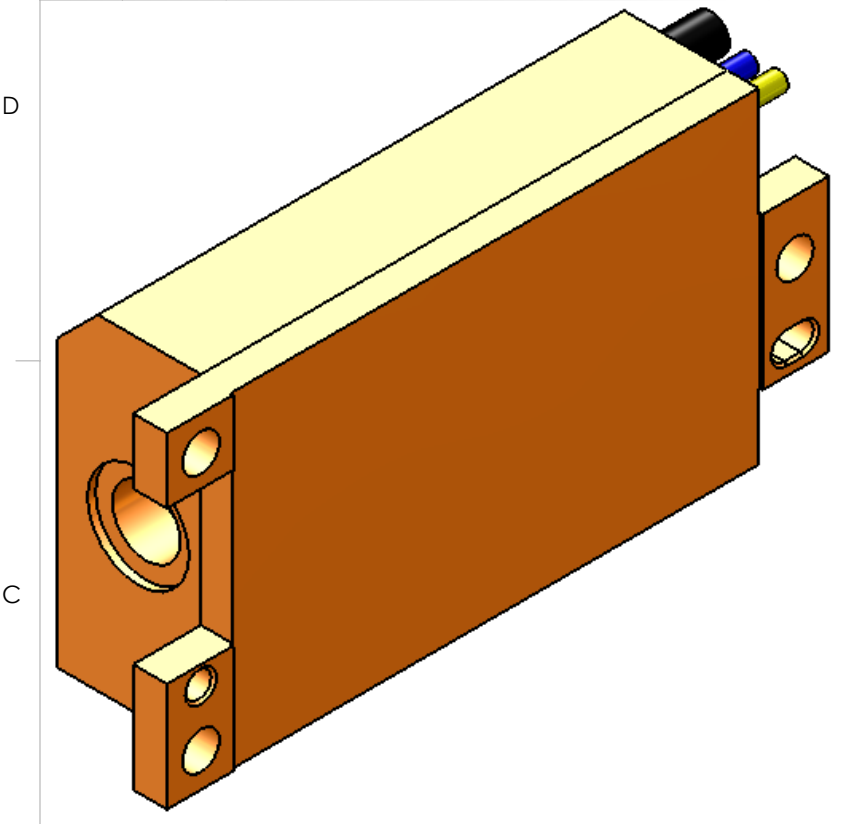

NOTE	DATE	DESCRIPTION	APPR

PROPRIETARY AND CONFIDENTIAL  
 THE INFORMATION CONTAINED IN THIS  
 DRAWING IS THE SOLE PROPERTY OF  
 <INSERT COMPANY NAME HERE>. ANY  
 REPRODUCTION IN PART OR AS A WHOLE  
 WITHOUT THE WRITTEN PERMISSION OF  
 <INSERT COMPANY NAME HERE> IS  
 PROHIBITED.

UNLESS OTHERWISE SPECIFIED:  
 DIMENSIONS ARE IN INCHES  
 TOLERANCES:  
 ONE PLACE DECIMAL ± 0.020  
 TWO PLACE DECIMAL ± 0.010  
 THREE PLACE DECIMAL ± 0.005  
 INTERPRET GEOMETRIC  
 TOLERANCING PER:  
 MATERIAL KOVAR  
 FINISH 32  
 DO NOT SCALE DRAWING

NAME	DATE
DRAWN CXY	09SEP09
CHECKED CRH	09SEP09
ENG APPR.	
MFG APPR.	
Q.A.	
COMMENTS:	

**KIGRE, INC.**

TITLE:  
**MK81 LASER OUTLINE**

SIZE <b>B</b>	DWG. NO. <b>B1611</b>	REV <b>0</b>
SCALE: 2:1	WEIGHT:	SHEET 1 OF 1