

INTRODUCTION

- ◆ Diode-pumped **Er-Yb bulk lasers** operating at 1.5 *mm* are very interesting **all-solid-state** sources for the following properties:
 - Narrow linewidth (a few tens of kHz)
 - High output power (a few tens of mW)
 - Good beam quality (TEM₀₀ mode)
 - Wide wavelength tunability (a few tens of nm)

- ◆ Potential applications in **Optical Communications, Metrology and Optical Measurements, High-resolution Spectroscopy**



OPTICAL COMMUNICATIONS

- ◆ **HDWDM** communication systems
- ◆ **Coherent** communication systems
- ◆ **Comb-generation** by multi-longitudinal-mode oscillation



METROLOGY AND OPTICAL MEASUREMENTS

- ◆ Absolute **frequency references** at 1.5 *mm*
- ◆ **Distance** measurements
with interferometric techniques
- ◆ **Distance and velocity** measurements
with coherent radar-laser techniques
- ◆ **Eye-safe** optical measurements in free-space



HIGH RESOLUTION SPECTROSCOPY

- ◆ **Widely tunable** single mode source
- ◆ **Narrow linewidth**
- ◆ **Frequency modulation** without amplitude variations



PURPOSE OF THE WORK

- ◆ Main goal: build Er-Yb microlasers stabilized with reference to absolute frequency standards
- Frequency standard: C₂H₂ transition lines around 1.5 *mm* (many deep and well resolved roto-vibrational lines)

- ◆ Preliminary requirement: new Er-Yb microlaser with
 - High power in single mode operation
 - Linearly polarized output
 - Wide continuous spectral tuning range
 - Narrow linewidth



THE SINGLE-MODE ER-YB MICROLASER

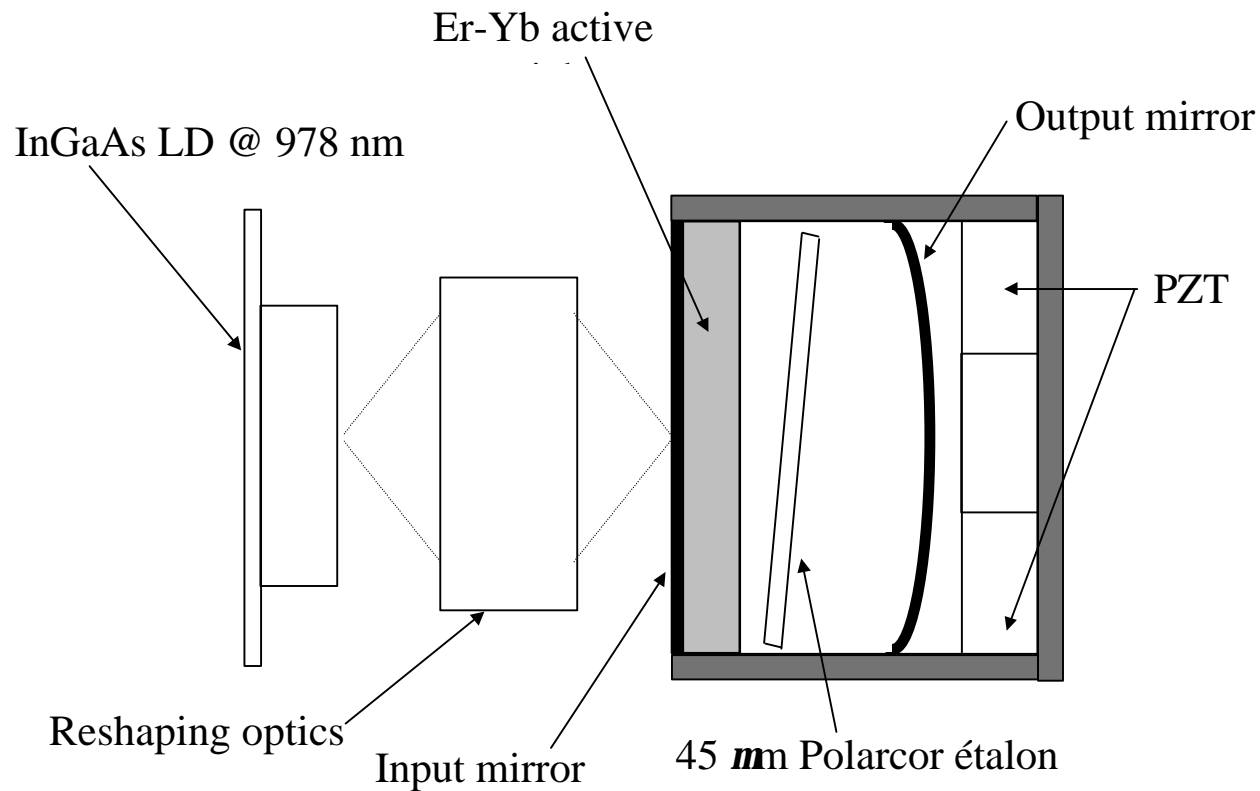

- Very compact cavity ($L=5$ mm)
- 45 **mm** Polarcor étalon: linear polarization + wide tunability
- PZT: frequency tuning for SLM operation



ER-YB MICROLASER PERFORMANCE

- High output power and Wide Tunability

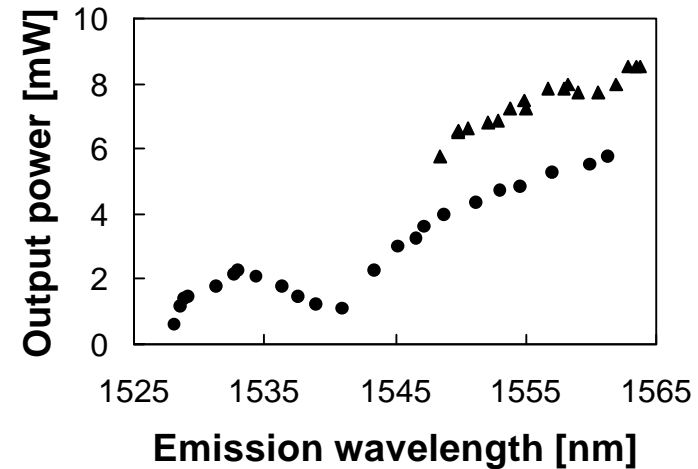
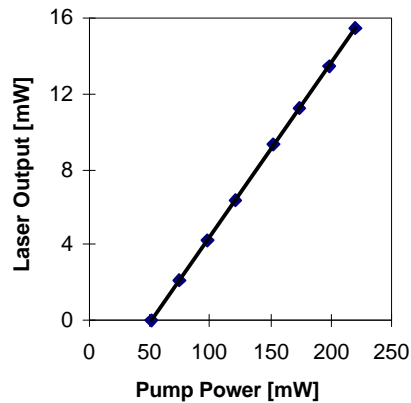

- >500:1 Linearly Polarized output
- Narrow Linewidth (~45 kHz)



THE MULTI-MODE ER-YB MICROLASER FOR OPTICAL COMB GENERATION

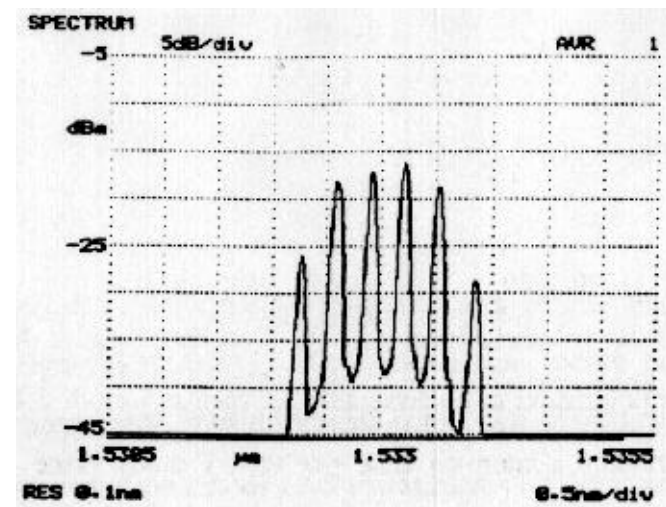
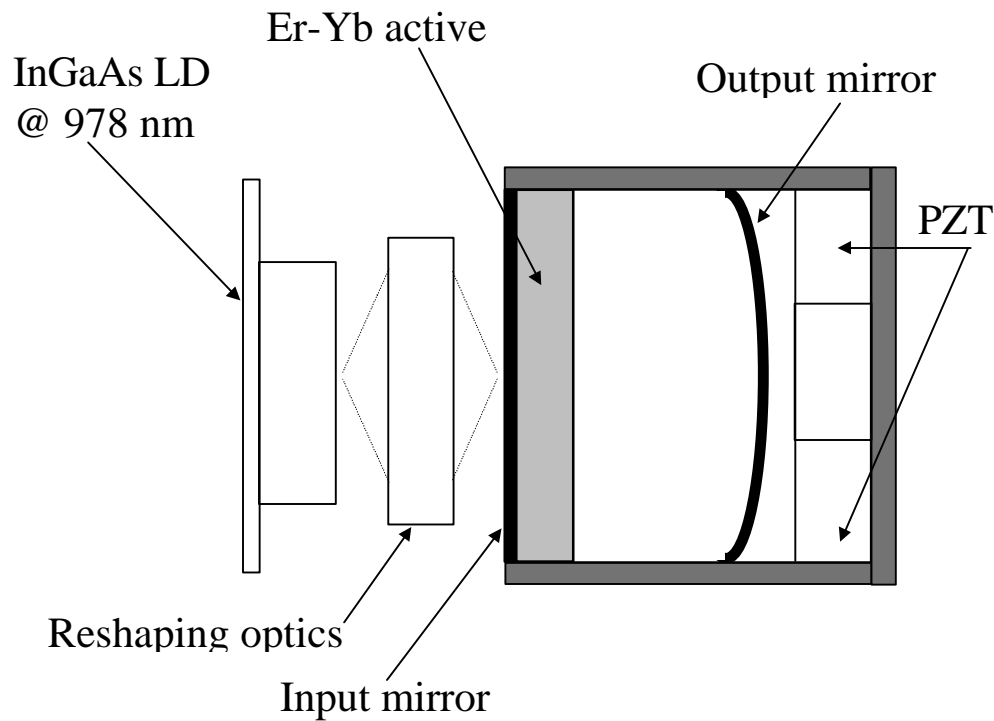

- Simultaneous oscillation over 5÷10 longitudinal modes with a frequency spacing of 40÷20 GHz.



STABILIZATION TECHNIQUES

- ◆ Absolute frequency stabilization against **C₂H₂ absorption lines**
- ◆ **Locking** by the *fringe-side-locking* technique
- ◆ **Locking** by the *FM-eterodyne* technique



THE FRINGE-SIDE-LOCKING TECHNIQUE

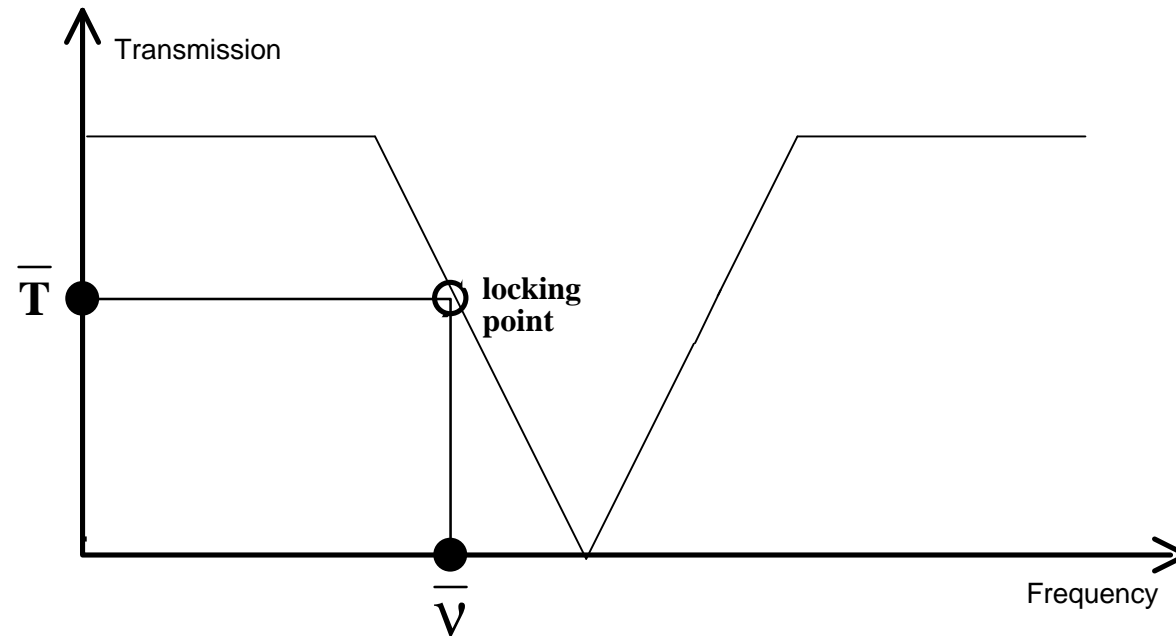

Transmission of the laser beam through a gas cell.

- The laser frequency is stabilized to the value $\bar{\nu}$ corresponding to the desired transmission \bar{T} of the molecular resonance by keeping the transmitted power fixed to a desired value



FRINGE-SIDE LOCKING EXPERIMENTAL SETUP

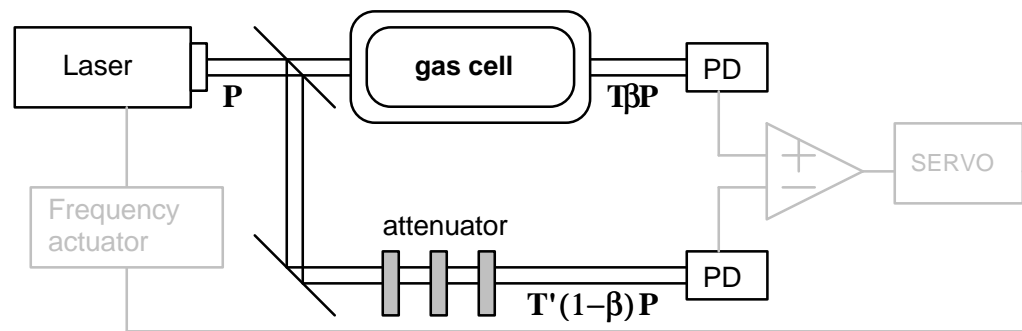

- The laser frequency is stabilized at the value $\bar{\nu}$ corresponding to a transmission \bar{T} of the gas cell
- Error signal: $E = A\{T\beta P - T'(1-\beta)P\}$



FM-ETERODYNE TECHNIQUE

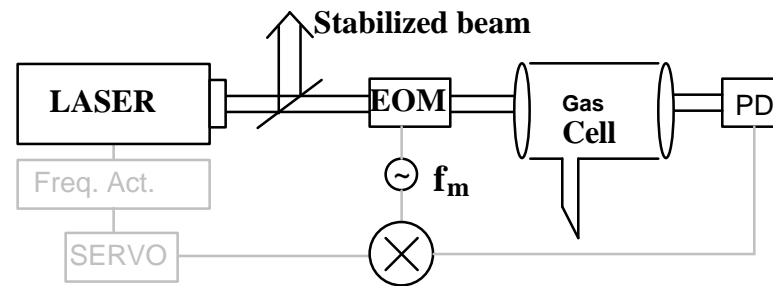

- The laser beam is frequency modulated, at the modulation frequency f_m , before passing through the gas cell
- Synchronous detection of the signal after the resonance
- Error signal: odd harmonics of f_m



THE ACETYLENE MOLECULE

- ◆ **Acetylene (C_2H_2):** strong roto-vibrational absorption lines spaced of ~ 80 GHz in the **spectral region 1510-1540 nm**

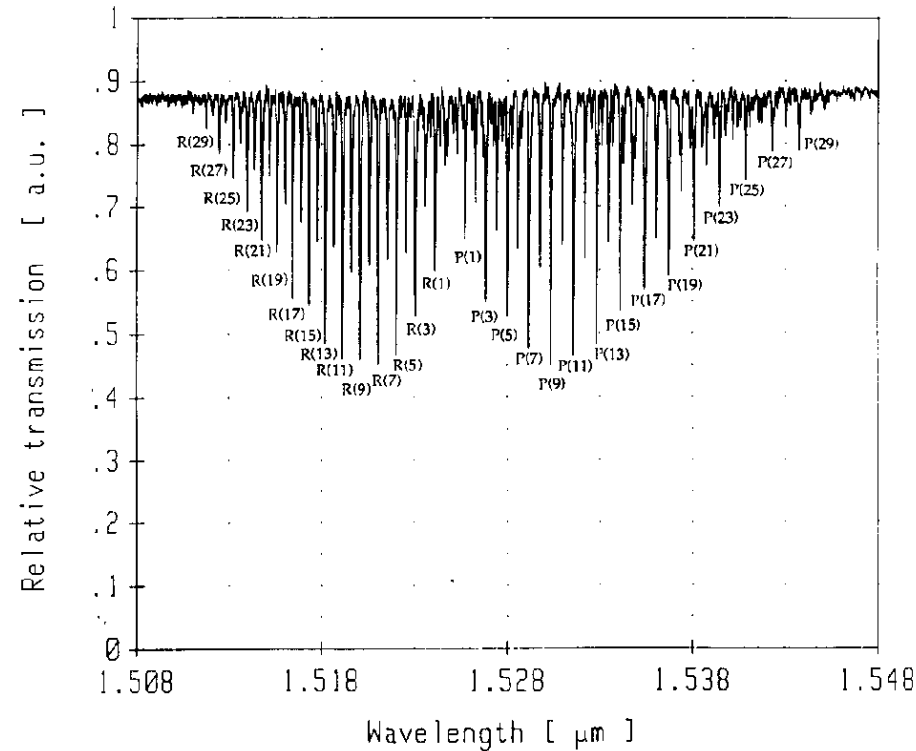

MEASUREMENT OF THE TRANSITION LINE P(13) OF C₂H₂

- ◆ The molecular transition of interest has been measured by the C₂H₂ cell upon frequency tuning the Er-Yb laser

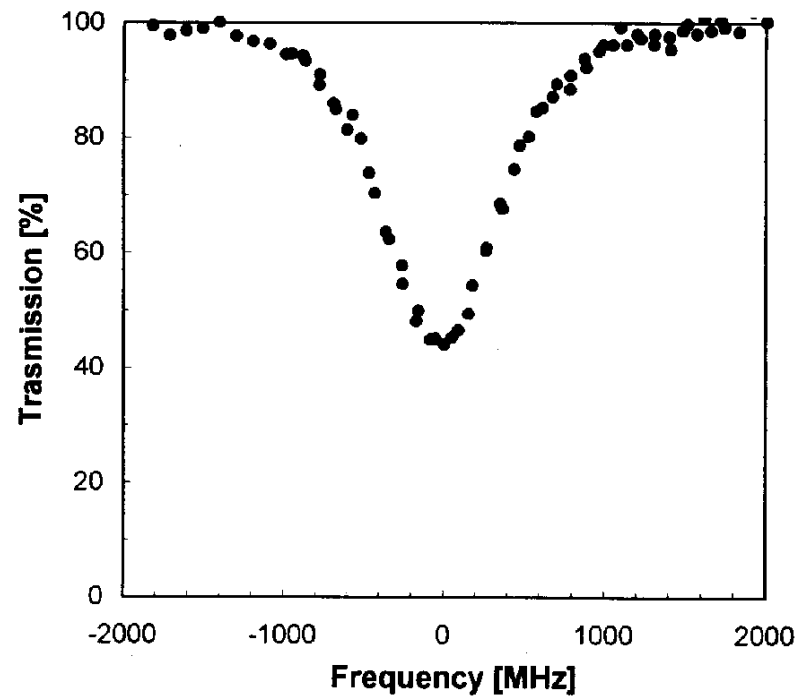

- ◆ Measured linewidth of the line P(13) ~700 MHz (Doppler)



OTHER TRANSITION LINES OF C_2H_2 AND $^{13}C_2H_2$

- ◆ Other molecular transitions of interest have been measured, both in C_2H_2 and $^{13}C_2H_2$ by the tunable Er-Yb laser

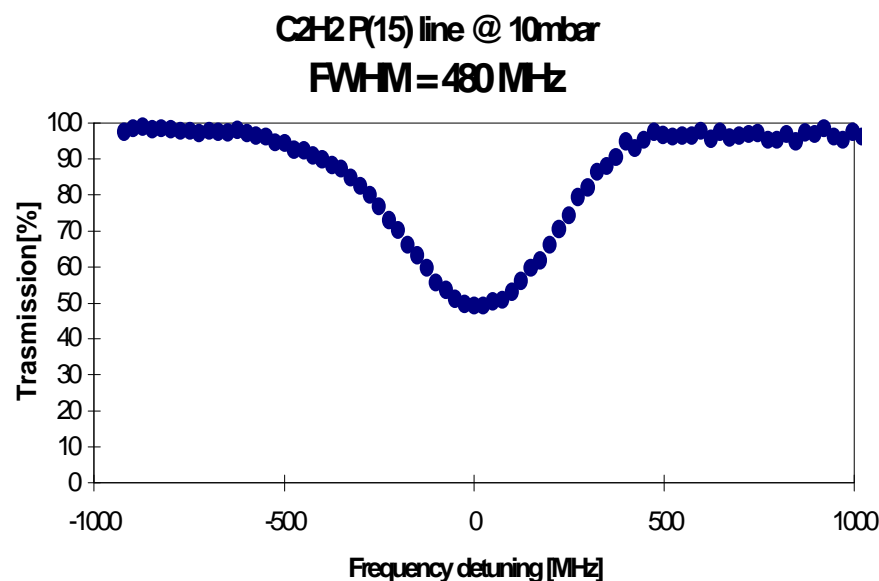

- ◆ In the 1540-1550 nm region, $^{13}C_2H_2$ lines from P(13) to P(29) have been measured ($\lambda = 1540.057 \text{ nm} \div 1550.870 \text{ nm}$)



FRINGE-SIDE-LOCKING STABILIZATION EXPERIMENT

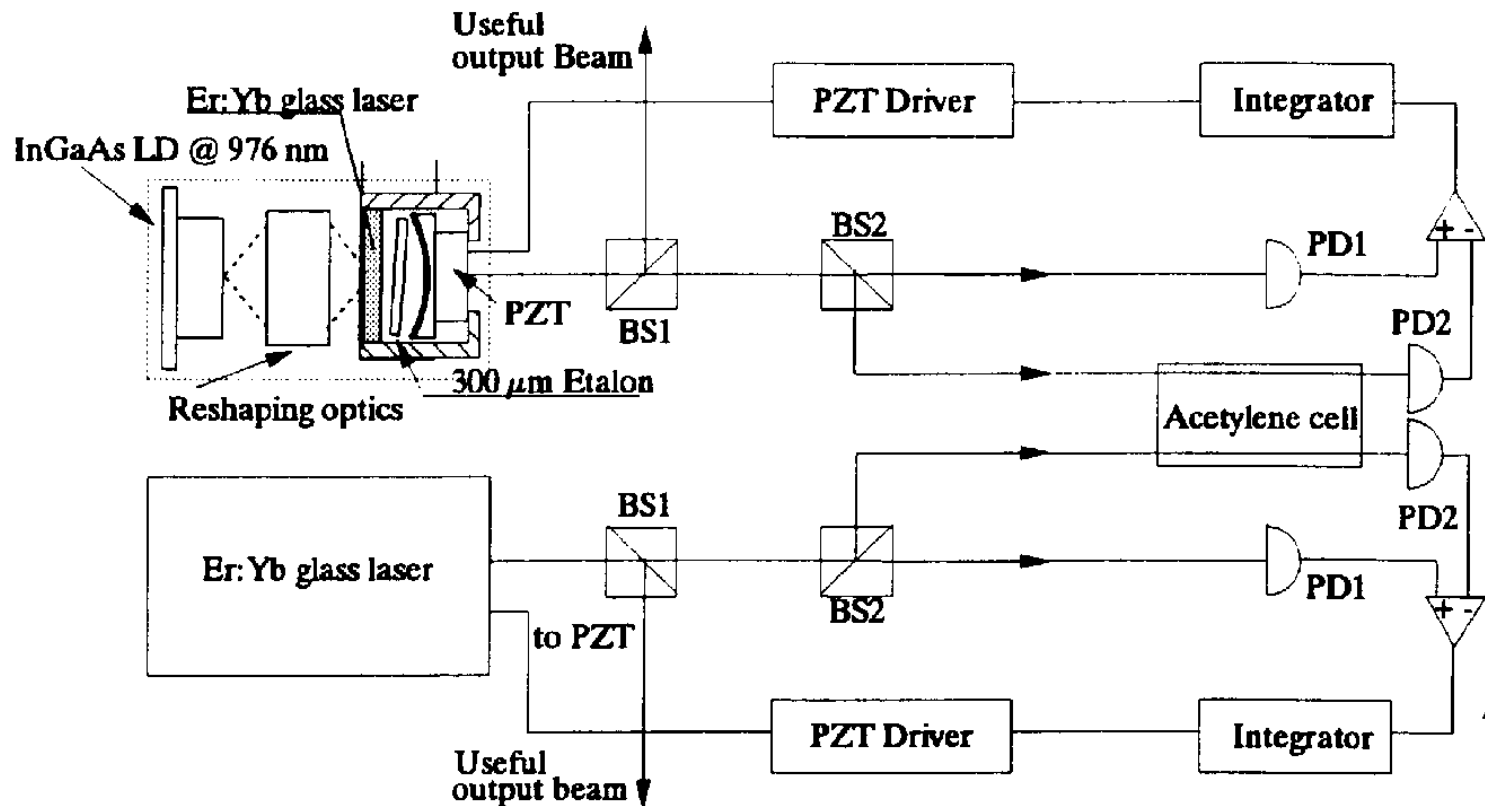

- ◆ **Two identical laser cavities** have been locked to the **P(13)** line of C_2H_2 at a **1532.828 nm** wavelength



SHORT TERM FREQUENCY STABILITY

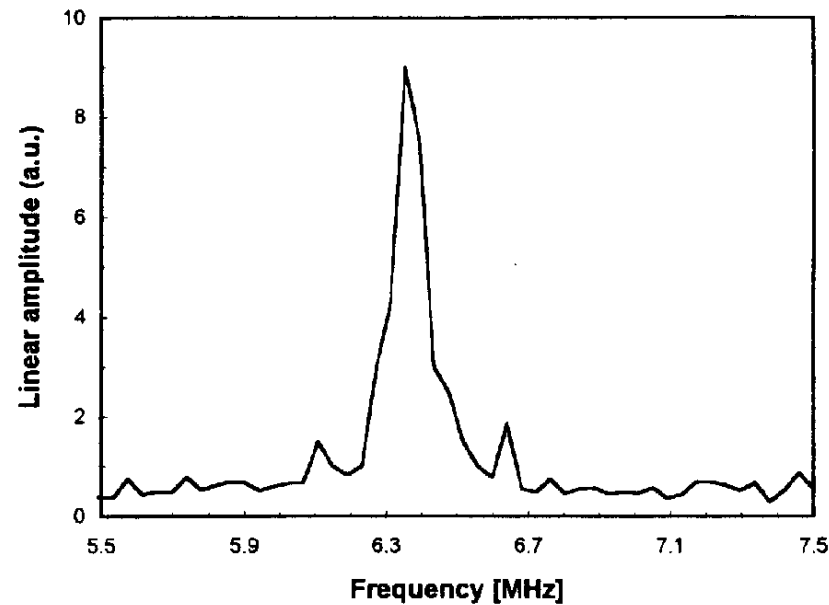

Spectral analysis of the two lasers beat note signal

- ◆ **Short-time frequency stability (1 ms) ~ 45 kHz**



LONG TERM FREQUENCY STABILITY

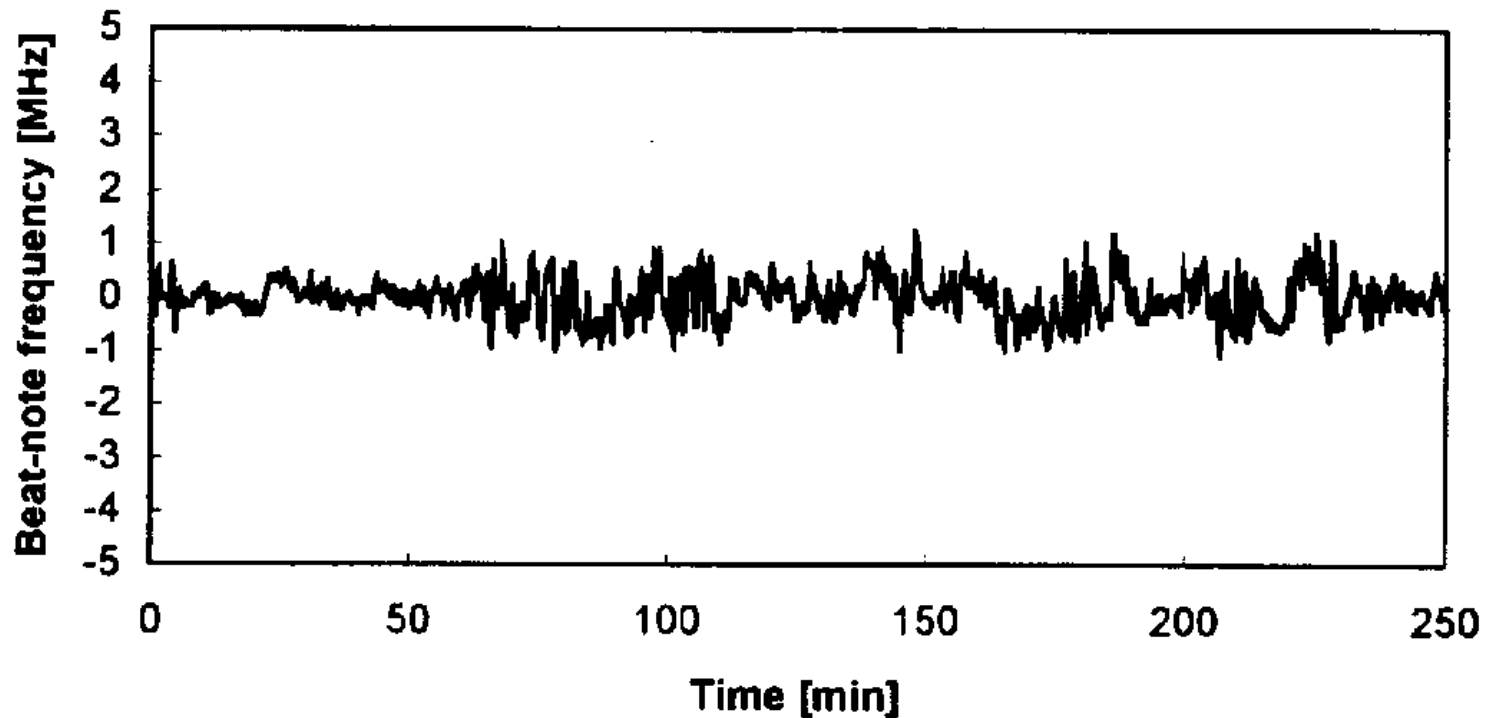

Time behaviour of beat-note frequency

- ◆ **Long-time frequency stability (4 hours) ~ 0.75 MHz**



FM-ETERODYNE STABILIZATION EXPERIMENT

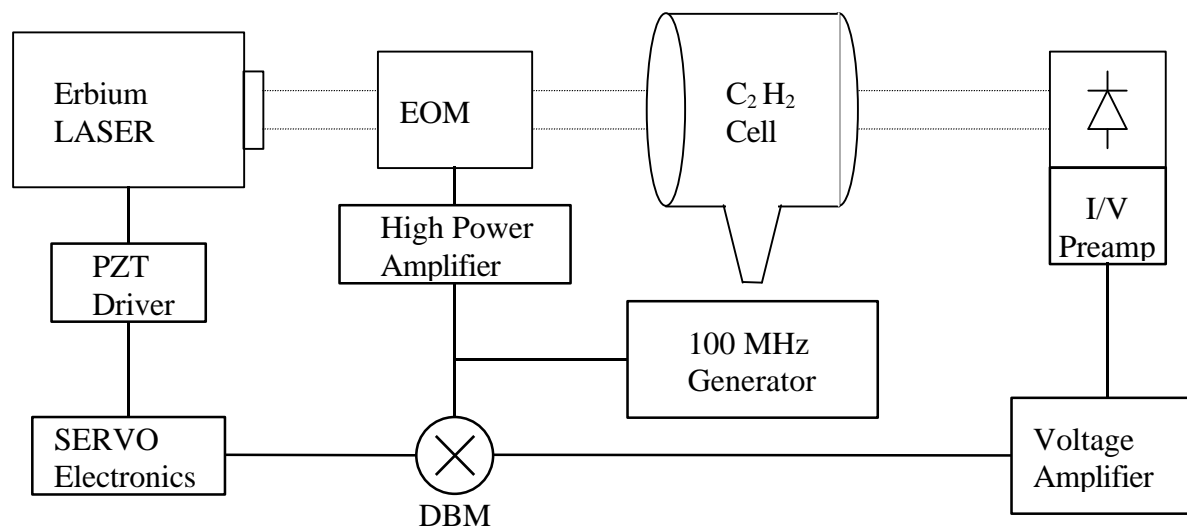

- ◆ Er-Yb microlaser locked to the **center of P(15) line** of C₂H₂ ($\lambda=1534.097$ nm)
- ◆ Error-signal, under closed-loop operation, observed to remain located to zero value \Rightarrow **frequency locking**



ERROR-SIGNAL ANALYSIS

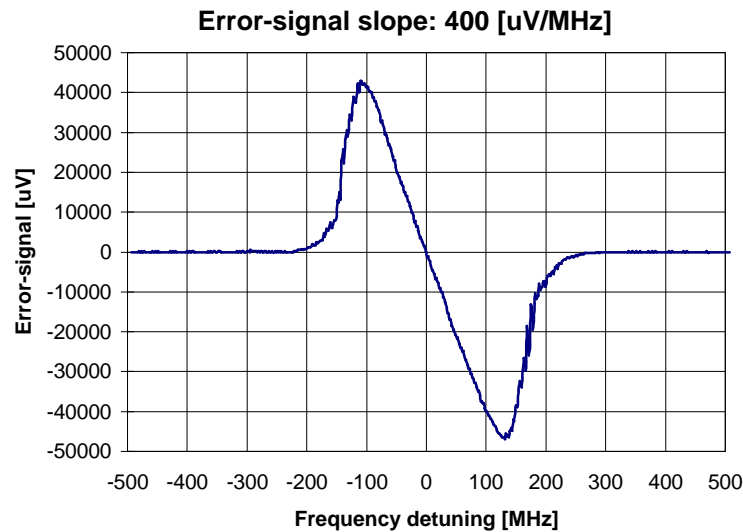

Discriminator curve

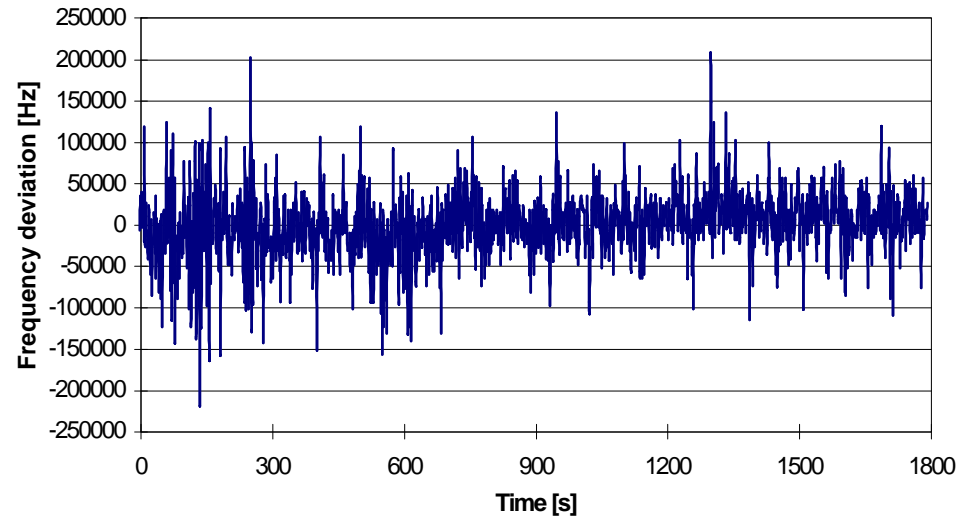

Closed-loop error-signal

- ◆ **Frequency fluctuations (0.5 hours) ~ 40 kHz rms ($Dn/n=2\times 10^{-10}$)**



CONCLUSIONS

- ◆ New **Er-Yb microlaser** provides **linear polarization, high power, wide tunability** (1528-1564 nm) in **single mode** operation
- ◆ **Fringe-side stabilization** of two Er-Yb lasers to **C₂H₂ molecule**
short term stability (1 ms) ~ **45 kHz**
long term stability (4 hours) ~ **0.75 MHz**
- ◆ **FM-eterodyne absolute frequency stabilization to C₂H₂ molecule** of a single Er-Yb laser: residual frequency fluctuations of ~ **40 kHz**
- The Er-Yb bulk microlaser is suitable for applications in **optical communications** (HDWDM, CATV), **spectroscopy** and **metrology**

